

Sperry Marine

VisionMaster FT ECDIS-E



The Solution to Paperless Navigation

VisionMaster FT ECDIS-E

Experience Counts

Sperry Marine is a leading provider of versatile and simple to operate ECDIS solutions. With a reputation for high performance and safe navigation, Sperry Marine is well positioned to meet the ever changing requirements of today's maritime market.

Building on the VisionMaster FT ECDIS legacy, the new VisionMaster FT ECDIS-E offers a cost effective solution for the retrofit market that complies with the latest performance standards.

Intelligent Functionality

Designed for ease of use and featuring a simplified menu structure, the VisionMaster FT ECDIS-E is based on the VisionMaster FT software platform, while optimised with Total Solid State (TSS) technology.

The key component is the Panel PC 24" Wide Screen Monitor that does not

contain movable parts; therefore, the VisionMaster FT ECDIS-E operates independently from the ship's vibrations, keeping it highly reliable with improved quality standards.

With VMFT ECDIS base line capabilities and standard sensor interfaces including gyro, speed logs and GPS, the VisionMaster FT ECDIS-E is a highly capable, low cost solution while still maintaining all the key safety features including Man Overboard as standard.

A configurable Conning Information Display (CID) tab provides the watch officer with key sensor inputs in an easy-to-read format that includes navigation information, engineering status and alarms to support safe and efficient vessel monitoring.

The VisionMaster FT ECDIS-E package provides a complete IMO-compliant Electronic Chart Display and Information System that meets the latest requirements for navigating without paper charts.

Features

- Panel PC 24" Wide Screen Monitor
- Easy installation
- Fully compliant with current type approval standards
 - IEC 61174
 - IEC 60945
 - IEC 62288

ECDIS-E Configuration

The VisionMaster FT ECDIS-E is based on the latest state of the art Panel PC technology, offering the ultimate in performance, convenience and high tech design for enduring quality. The Panel PC is a flexible all-in-one solution designed for reliability and versatility, providing a robust solution for all ship installations. Innovative hardware adopts the latest solid state drive technology, removing vibrations that affect standard rotating hard disk drives.

Ship Type	Ship Size	Construction Date	Requirement ECDIS
Passenger	>500GT	Before July 2012	July 2014
	>500GT	Since July 2012	July 2012
Tanker	>3000GT	Before July 2012	July 2015
	>3000GT	Since July 2012	July 2012
Cargo	>50000GT	Before July 2013	July 2016
	>20000GT	Before July 2013	July 2017
	>10000GT	Before July 2013	July 2018
	>10000GT	Since July 2013	July 2013
	>3000GT	Since July 2014	July 2014

The IMO has recently defined new carriage requirements for ECDIS, depending on vessel's type, size, and date of construction.

Sensor Interfacing	ECDIS Min. Perf. Req.	VisionMaster FT EDCIS-E
Gyro	Yes	Yes
Speed Log	Yes	Yes
GPS	Yes	Yes
Key Features	ECDIS Min. Perf. Req.	EDCIS-E
Route Management	Yes	Yes
Chart Presentation Size	270mm x 270mm	284mm x 531mm ¹
Clearing Lines	Yes	Yes
Mariner Objects	Yes	Yes
Target Management	Yes	Yes
Data Logins	Yes	Yes
ERBL, Range Rings, CPA & TCPA	Yes	Yes
Additional Capabilities	ECDIS Min. Perf. Req.	EDCIS-E
AIS Overlay	No	Yes
Tracked Target Overlay	No	Yes
Man Overboard	No	Yes
Conning Information Display (CID)	No	Yes ²
ETA Calculator	No	Yes
Lat/Long Grid	No	Yes
User Profiles	No	Yes
Diagnostic Reporting	No	Yes
Maximum Number of Nodes	-	2
Available Chart Formats: - S57, S-63, Direct ENC - C-MAP Charts - ARCS		Yes Yes Yes
Mounting Configurations		EDCIS-E
Kit Format for back Consoles Mounting	-	Yes
Kit Format for front Consoles Mounting	-	Yes
Kit Bracket Mounting (desk/deckhead)	-	Yes

¹ Size - With CID side panel set off

² CID - Available as side panel and has to be configured by the commissioning engineer

Technical Data

- Monitor Type: Flat Panel PC
- Screen Size: 24.0" diagonal
- Resolution: 1920 x 1080 (16:9)
- Contrast Ratio: 3000:1 typical
- Luminance: 300 cd/m² typical
- Power Supply Input: Multi-power
115/230VAC,
50/60Hz + 24VDC
- Consumption: 125W max
- Human Interface: Tracker Ball
- Environmental Specifications: IEC60945
- Type Approval: IEC61174,
IEC62288
- Temperature:
 - Operating: -15.0°C to 55.0°C
 - Storage: -20.0°C to 60.0°C
- Compass Safe Distance:
 - Standard: 1.15m
 - Steering: 0.7

Sperry Marine

VisionMaster FT ECDIS-E in Paperless Configuration

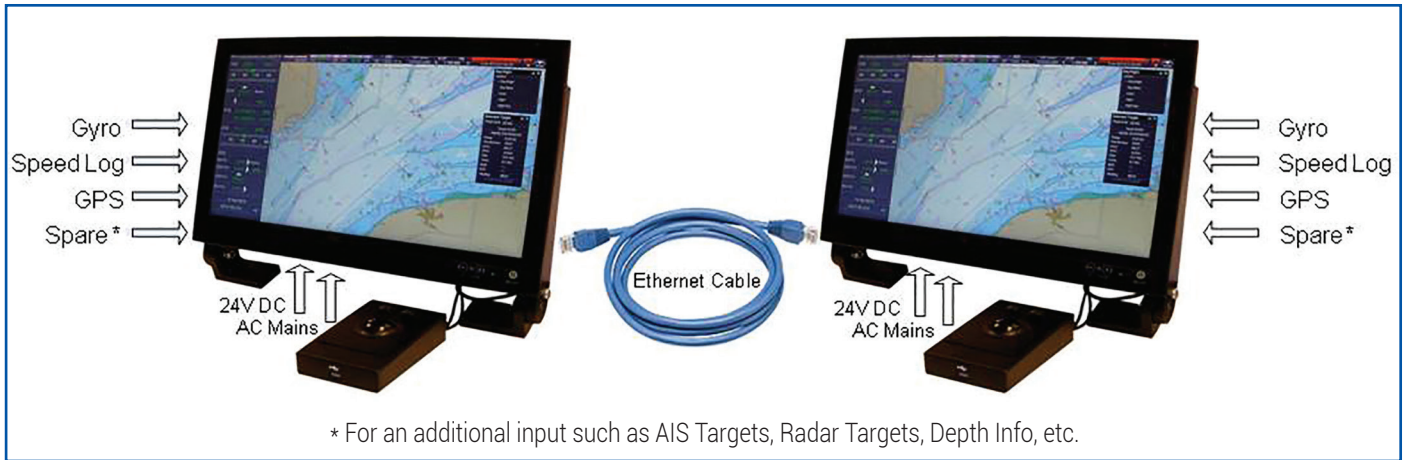

Configuration

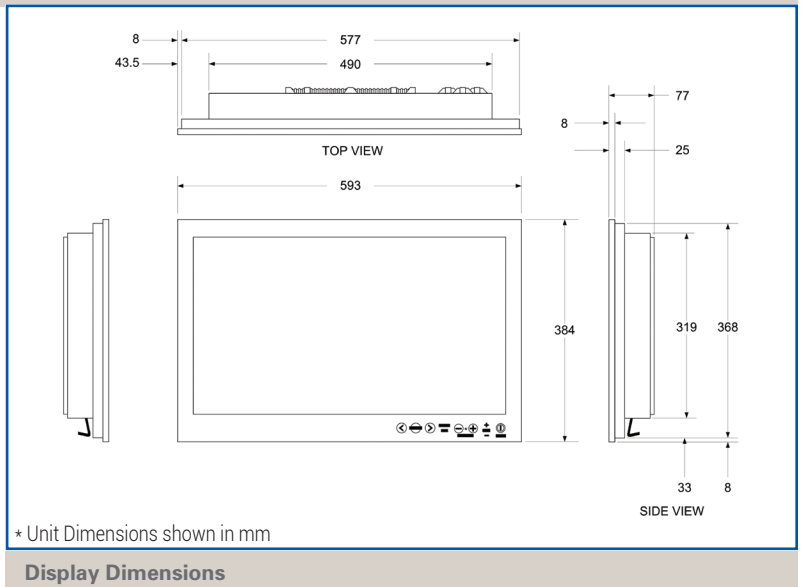
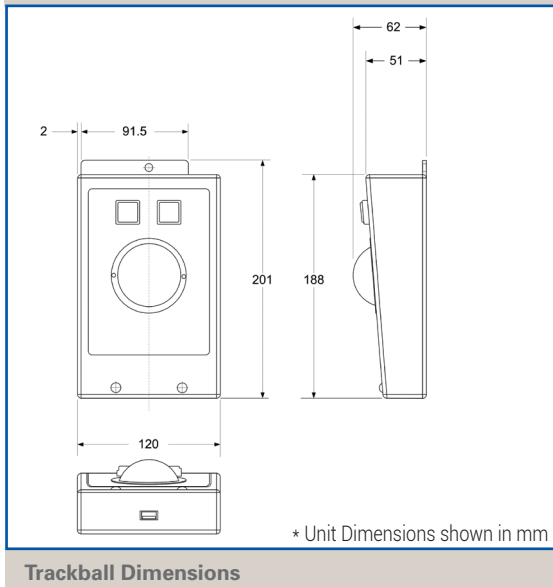

For more information, please contact:

AMERICAS

New Orleans, LA USA
Tel: +1 504-328-9171

ASIA

China, Shanghai
Tel: +86-21-5179-0199

Hong Kong, Sheung Wan
Tel: +852-2581-9122

Japan, Tokyo
Tel: +81 (03)-3863-7401

Singapore
Tel: +65-6274-3332

South Korea, Busan
Tel: +82-55-544-7458

CANADA

Nova Scotia, Halifax
Tel: +1 902-468-9479

British Columbia, Vancouver
Tel: +1 604-821-2090

EUROPE

Belgium, Antwerp
Tel: +32-3-233-14-33

Denmark, Copenhagen
Tel: +45-77-33-66-33

Germany, Hamburg
Tel: +49-40-299-00-0

The Netherlands, Vlaardingen
Tel: +31 (0)-10-4451600

Norway, Bergen
Tel: +47-55-94-94-94

United Kingdom, London
Tel: +44 (0)-20 8329-2000